

REVISIONS

REV.	DESCRIPTION	DATE	APPROVED
A	Diverse aanpassingen	17-08-2022	H.P.
B	10mm lager nieuw gat in koker, oude dicht lassen, nieuw type voetpl met gat tbv LED dop	12-10-2022	H.P.
C	extra plaatje middenin	18-10-2022	H.P.

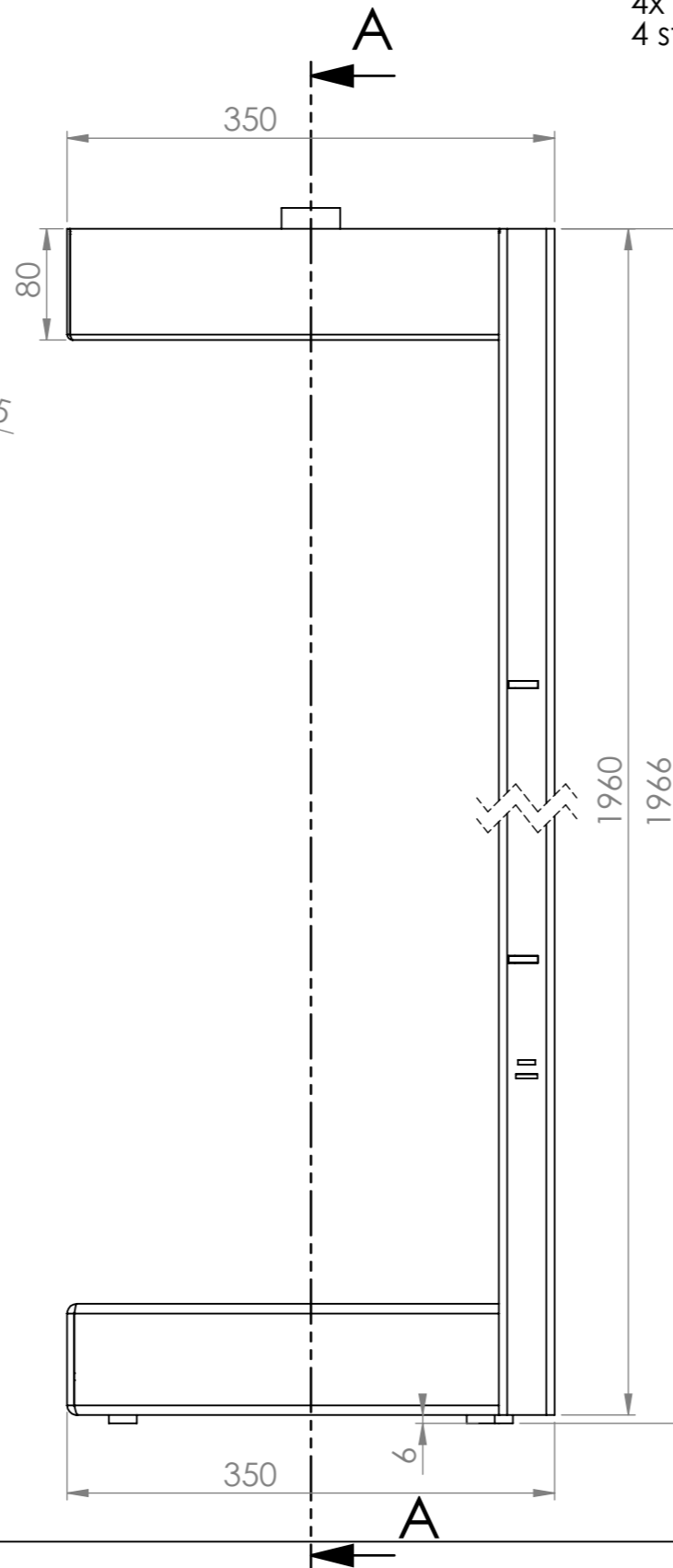

Bevestigingsmateriaal per lamp:
 7x stift M4x16
 2x stift M4x25
 4x verzonkenkopbout M4x16
 4 stelpoten M8

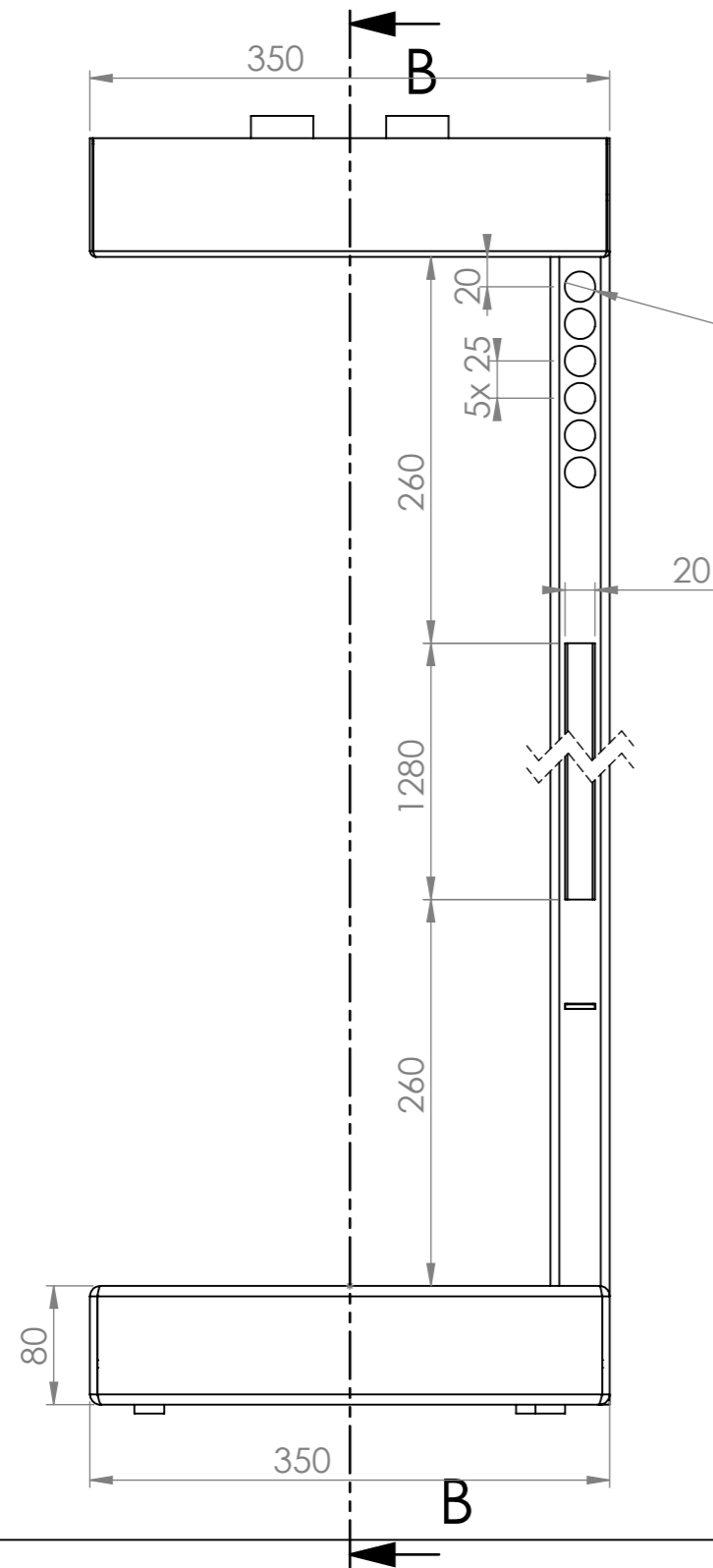
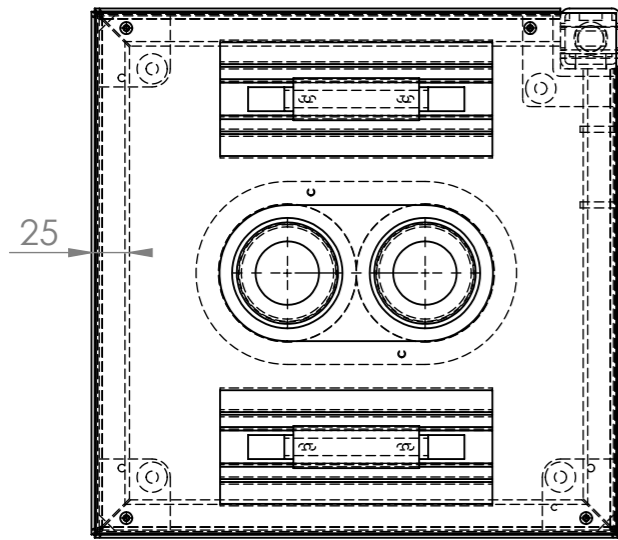
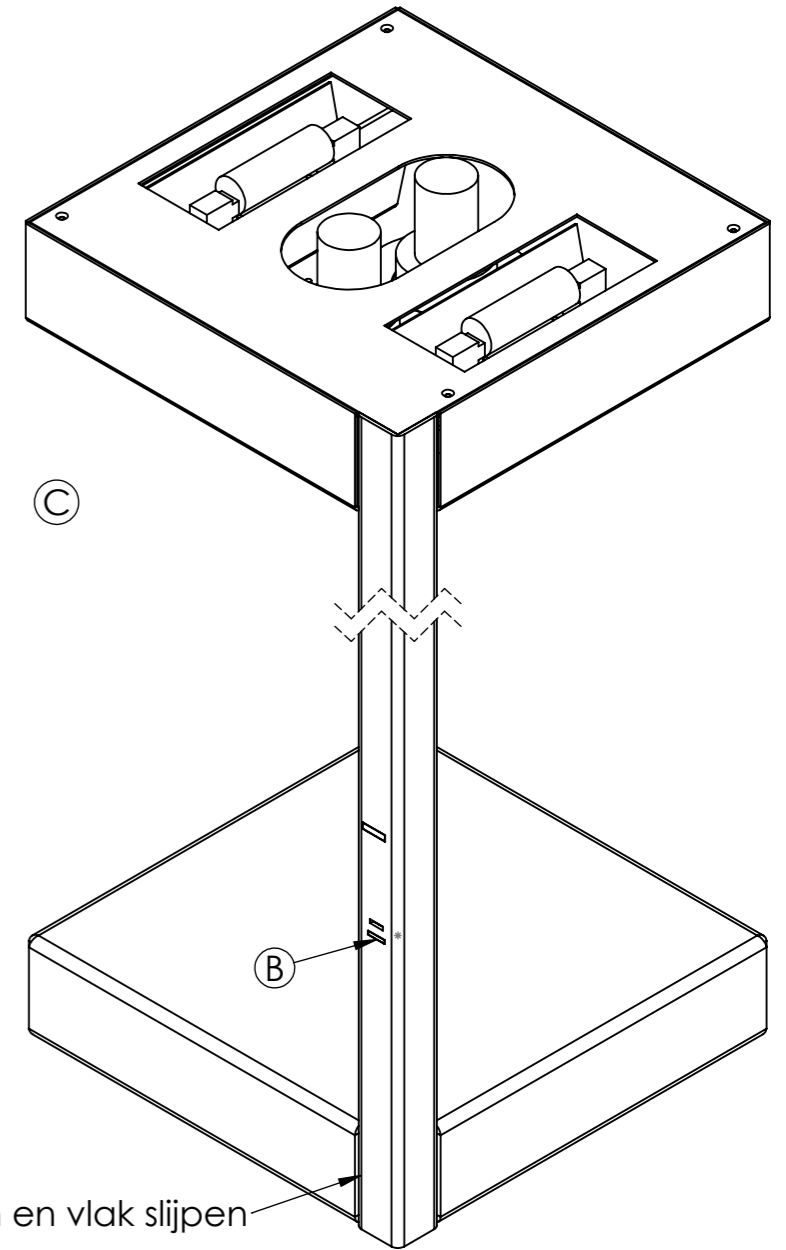

2x als getekend,
 2x gespiegeld uitvoeren.
 Betekent dat alleen de koker gespiegeld uitgevoerd wordt,
 de rest is allemaal 'verdaaibaar'. Tijdens samenstellen 2 versies maken.

Titel	Armatuur staander		
Opdrachtgever	PSO B.V.		
Werk			
Conservering	PC RAL9016 fijn structuur		
Project nr.	220788.1	Materiaal	S235
Tek. nr.	Armatuur staander rev B	Gewicht	29.36 kg
Getekend	D.H. Pater	W. ten Ham Plaatwerk B.V.	
Datum	19-07-2022	Schampsteeg 1B 6718 VD Ede	
Formaat	A3	Eenheid	mm
Schaal	1:5	Am. Projectie	⊕ ⊖
		Mail: info@tenhamplaatwerk.nl	
		www.tenhamplaatwerk.nl	
		www.cortenstaal.com	

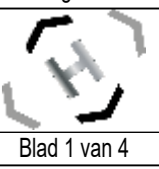

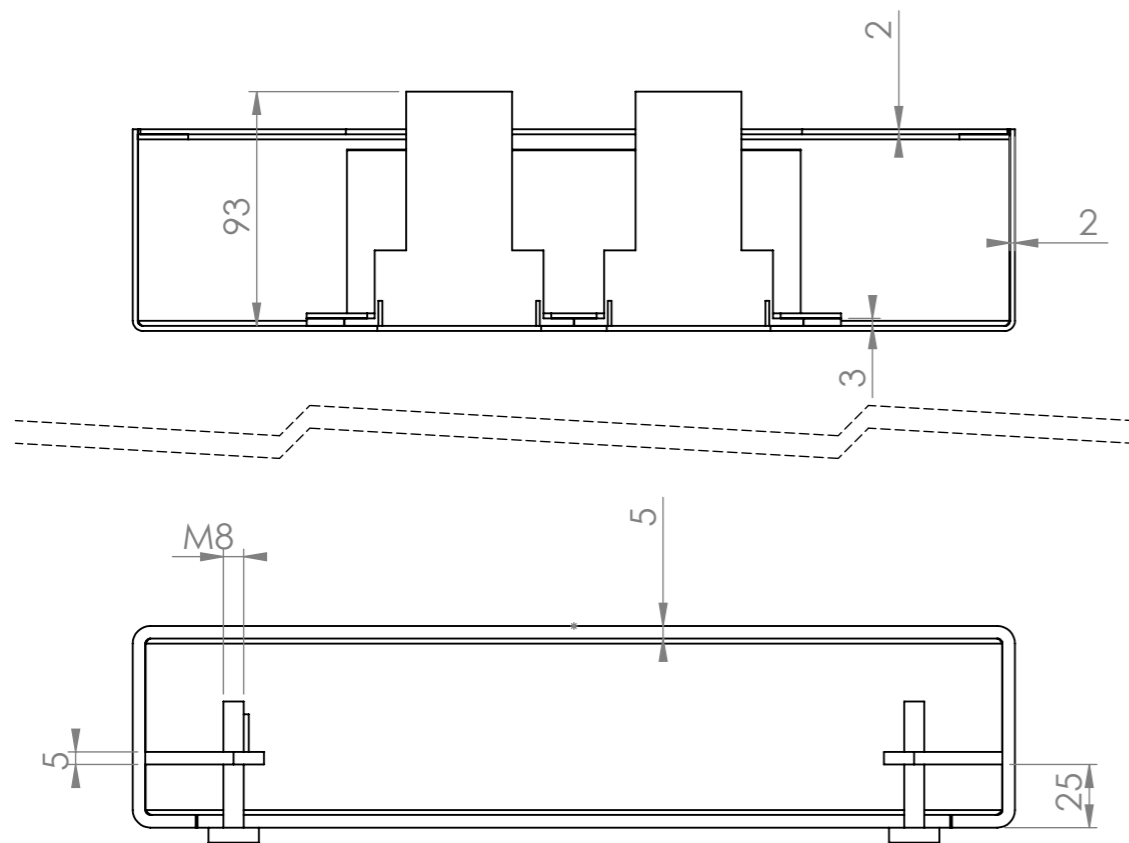

SECTION A-A
SCALE 1 : 3

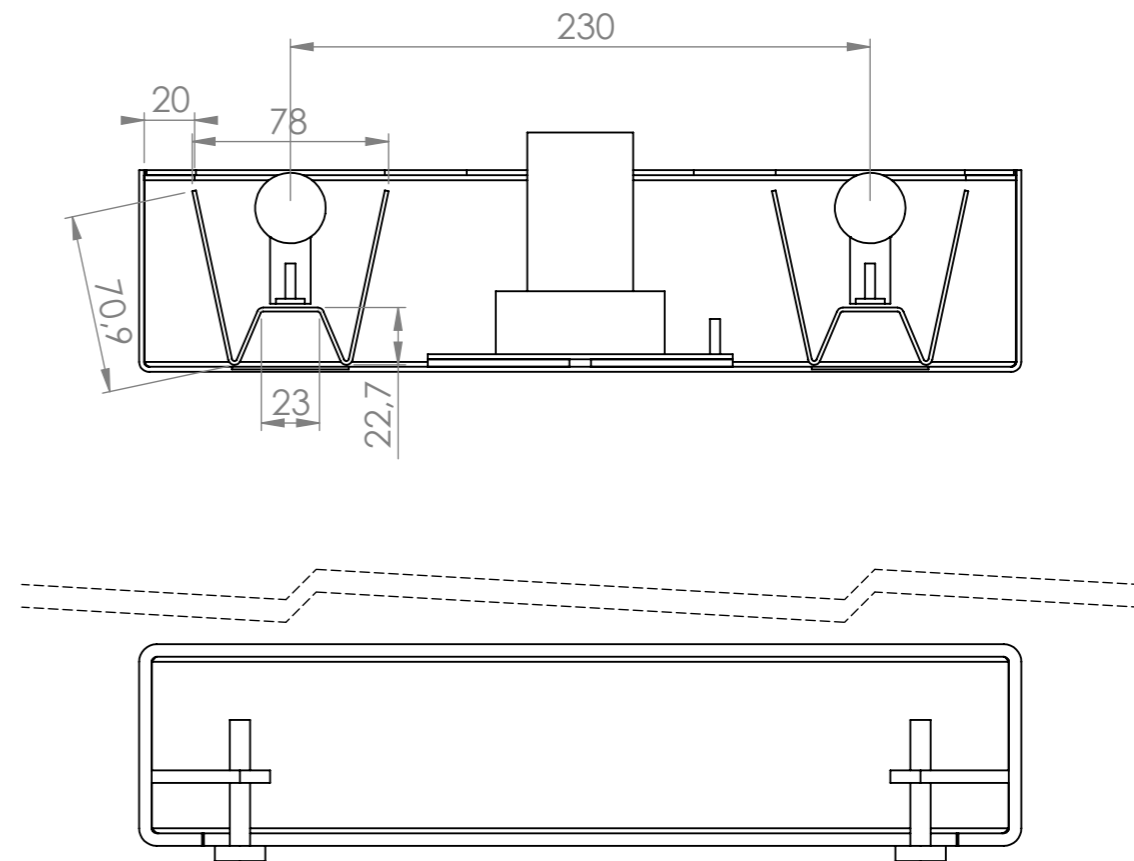

SECTION B-B
SCALE 1 : 3

Beschrijving:					
Oprachtgever	PSO B.V.				
Conservering	PC RAL9016 fijn structuur				
Project nr.	220788.1	Materiaal	S235		
Tek. nr.	Armatuur staander rev B	Gewicht	29.36 kg		
Getekend	D.H. Pater	W. ten Ham Plaatwerk B.V. Schampsteeg 1B 6718 VD Ede Tel: 0318-576499 Mail: info@tenhamplaatwerk.nl www.tenhamplaatwerk.nl www.cortenstaal.com			
Datum	19-07-2022				
Formaat	A3			Eenheid	mm
Schaal	1:5			Am. Projectie	
			Blad 2 van 4		



Voetplaat

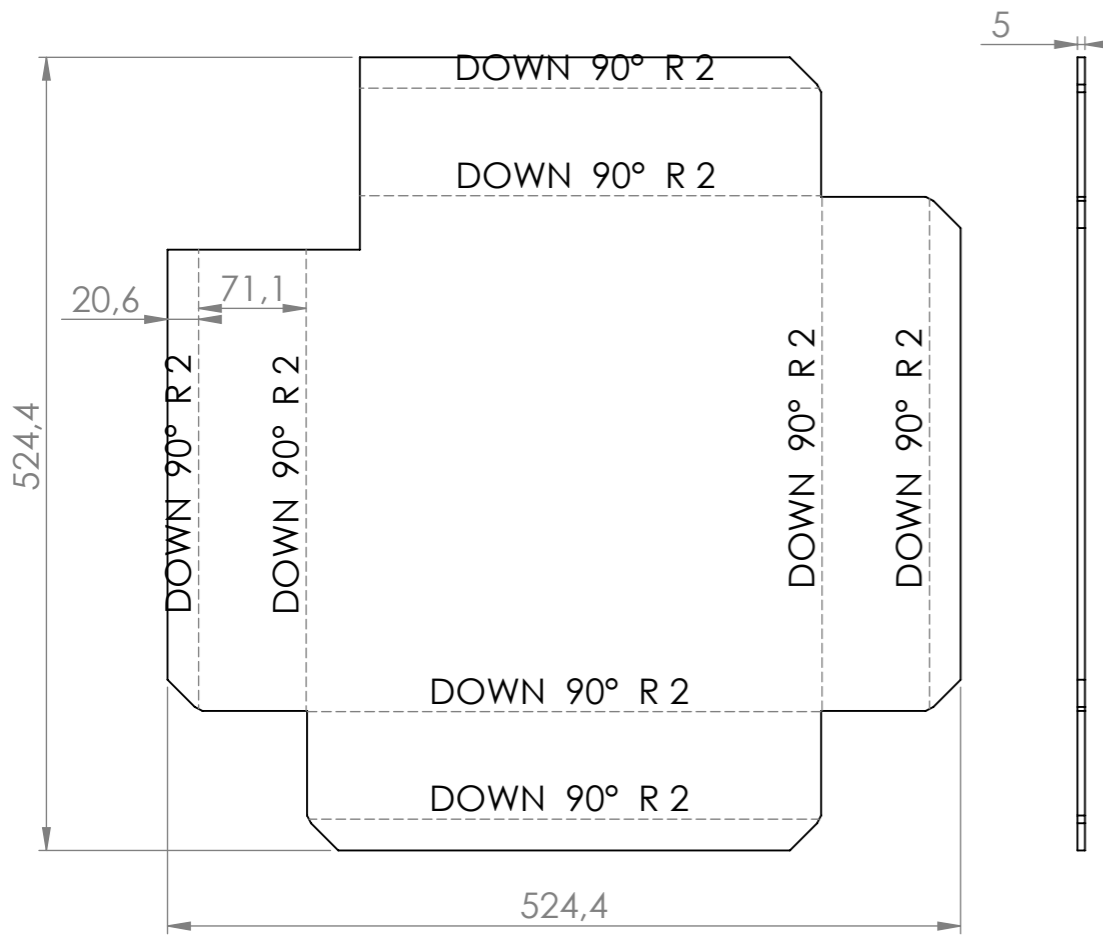

3x voetpl
1 hoeft er maar een opgelaste stift

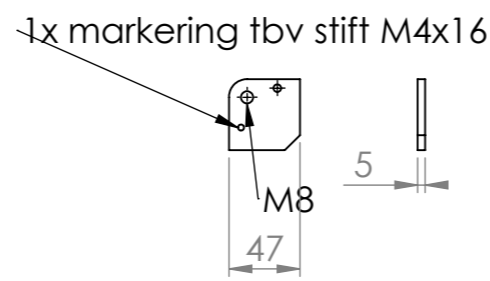

1x voetpl

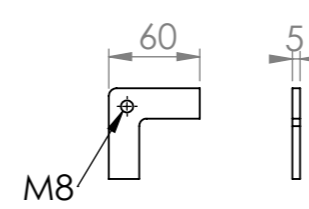

1x voetpl tl

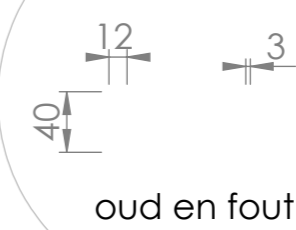

1x voetpl plexiglas

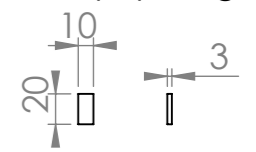

oud en fout

1x klemplaat spots

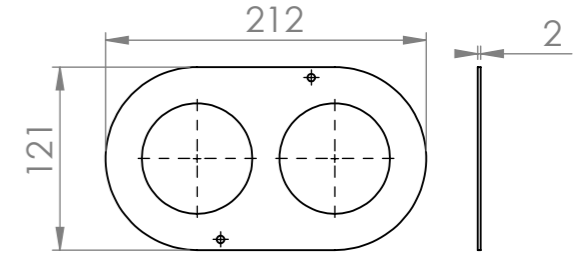

2x geleidepl TL

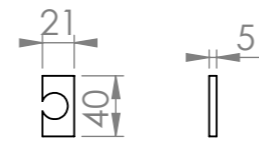

2x geleidepl plexiglas

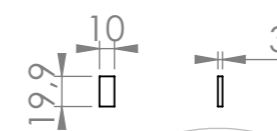

nieuwe voetpl TL

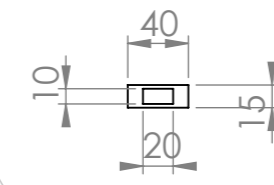

1x vulplaat spots

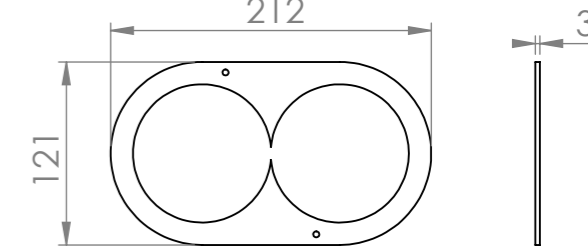

1x bovenplaat

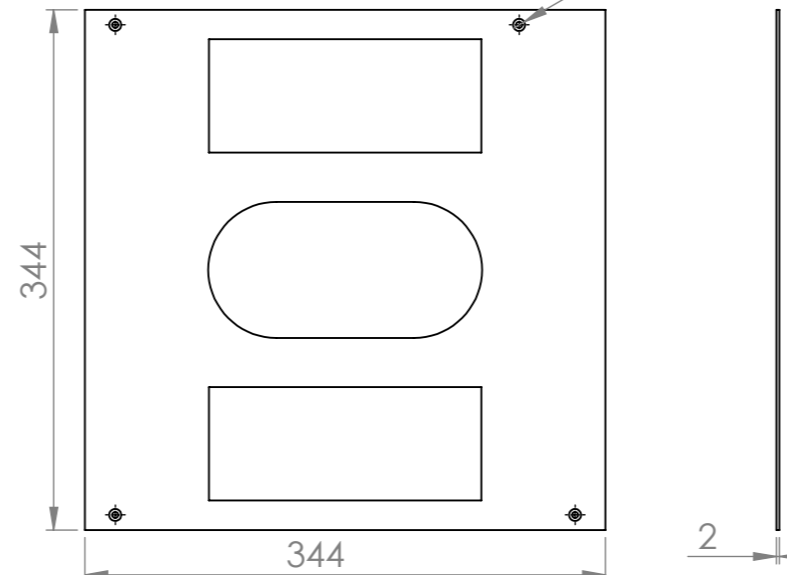

2x markering tbv stift M4x25

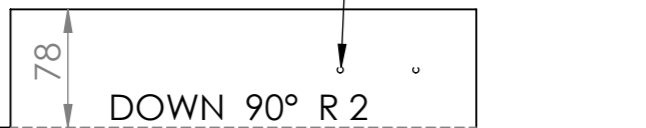

2x markering tbv stift M4x16

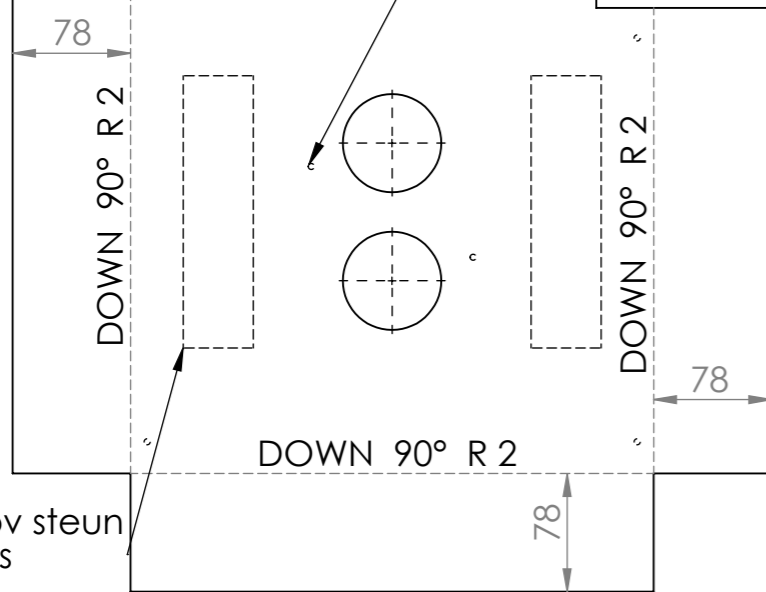

Bovenbak
op z'n kop snijden ivm markering

Markering tbv steun
bovenstralers

2x steun bovenstralers

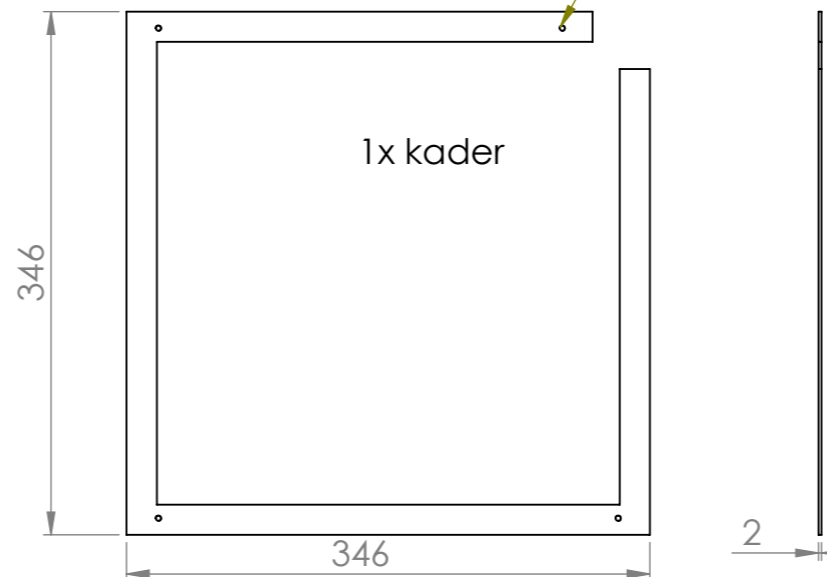
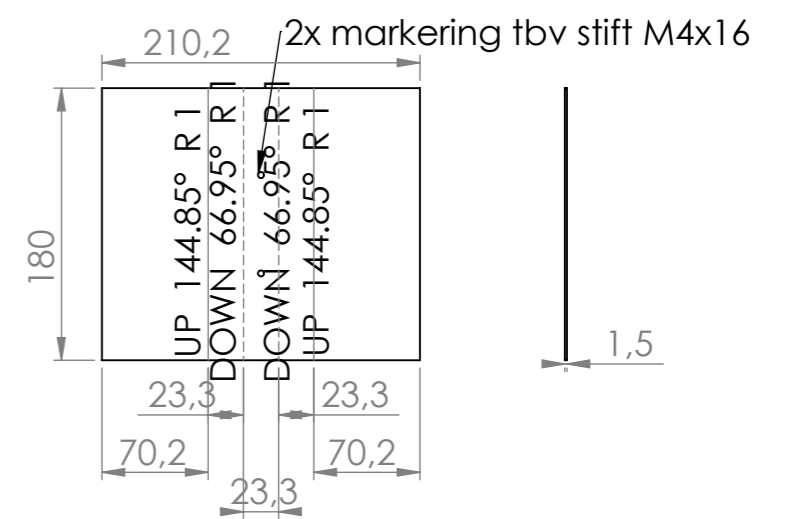

Beschrijving:	Alle uitslagen		
Opdrachtgever	PSO B.V.		
Conservering	PC RAL9016 fijn structuur		
Project nr.	220788.1	Materiaal	S235
Tek. nr.	Armatuur staander rev B	Gewicht	29.36 kg
Getekend	D.H. Pater	W. ten Ham Plaatwerk B.V.	
Datum	19-07-2022	Schampsteeg 1B 6718 VD Ede	
Formaat	A3	Eenheid	mm
Schaal	1:5	Am. Projectie	www.tenhamplaatwerk.nl
			www.cortenstaal.com



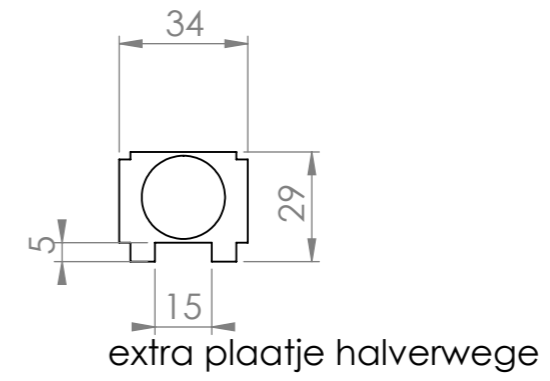
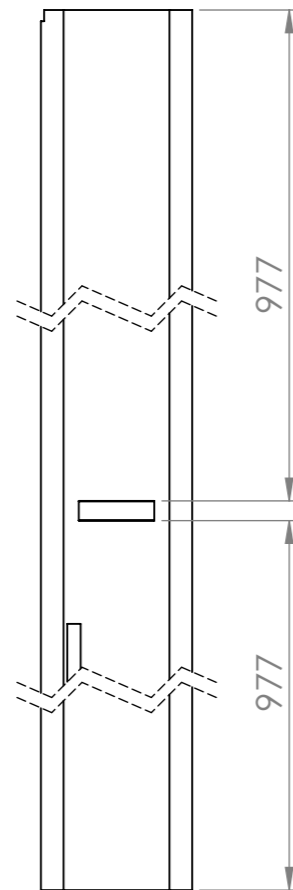
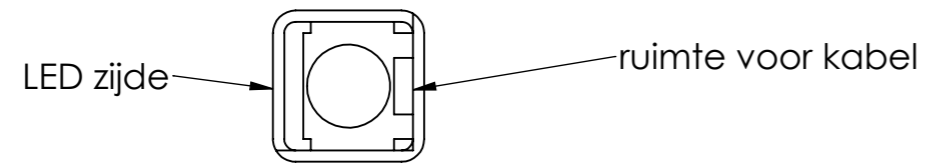

Beschrijving:				
Oprachtgever	PSO B.V.			
Conservering	PC RAL9016 fijn structuur			
Project nr.	220788.1	Materiaal	S235	
Tek. nr.	Armatuur staander rev B	Gewicht	29.36 kg	
Getekend	D.H. Pater	W. ten Ham Plaatwerk B.V. Schampsteeg 1B 6718 VD Ede Tel: 0318-576499 Mail: info@tenhamplaatwerk.nl www.tenhamplaatwerk.nl		
Datum	19-07-2022			
Formaat	A3			Eenheid
Schaal	1:2	Am. Projectie		
			www.cortenstaal.com	Blad 4 van 4